



EXIDE **POWERSAFE EHP**

Premium Range of Data Center Batteries



Product Range

Battery Type	15min Power Rating up to 1.67 VPC	Dimension (L X W X H) in mm	Sp. Power (W/Kg)	Internal Resistance (m Ω)
EHP12-390W	390W	407 X 173 X 235	67	4.90
EHP12-440W	440W	452 X 172 X 239	66	4.35
EHP12-540W	540W	536 X 186 X 250	67	3.70
EHP12-730W	730W	533 X 250 X 250	65	3.15

Features

- ▶ High energy density and specific power as compared to regular SMF batteries
- ▶ Double sealed robust terminals, 100% ensured during manufacturing.
- ▶ Reinforced ribbed container ensuring robustness.
- ▶ Lower IR values ensuring quick charge.
- ▶ Batteries can be discharge up to 10.02V.
- ▶ Ca-Sn Alloy for less gassing and low self discharge

Charging Parameters

Mode of Operation	Voltage setting per 12V unit for ambience Temp. 20°-30°C
FLOAT	13.7V \pm 0.1V
BOOST	14.1V \pm 0.1V

Temperature Compensation (Reference Temp- 25°C): -18mV/°C/12V unit

- String equalization in boost mode once in 3 months for 16-24 hours

Construction

- ▶ Positive and negative plates in lead-tin-calcium alloy.
- ▶ Separator - low resistance micro porous glass fiber.
- ▶ The electrolyte is absorbed within this material, preventing acid leakage in case of accidental damage.
- ▶ Terminals with a large surface area to provide maximum conductivity.
- ▶ Self-regulating pressure relief valve.
- ▶ Stronger, sturdier & attractive packaging.
- ▶ Especially suited for UPS & Power Application.

Effect of temperature on Power

104°F (40°C)	102%
77°F (25°C)	100%
32°F (0°C)	82%
5°F (-15°C)	62%

Gas Evolution

Under worst case operating condition, the below table to be referred for calculation of hydrogen gas evolution per battery

Battery Type	Rate of hydrogen evolution
EHP12-390W	0.00057 m ³ /hr
EHP12-440W	0.00068 m ³ /hr
EHP12-540W	0.00084 m ³ /hr
EHP12-730W	0.00111 m ³ /hr

Air Flow Calculation

Required Air Flow

$$= d \times s \times (\text{hydrogen gas evolved per hour from battery bank}) \text{m}^3/\text{hr}$$

$$d = \text{dilution ratio} = (100-4)/4 = 24;$$

Lower explosive limit for Hydrogen= 4% below which the air mixture will be to lean to burn

s= factor of safety, e.g. s = 5

Heat Generation

Under worst case operating condition, the below table to be referred for calculation of heat generation during charging per battery

Battery Type	Rate of Heat Generation
EHP12-390W	2.84W
EHP12-440W	3.38W
EHP12-540W	4.19W
EHP12-730W	5.54W

Float Service Life

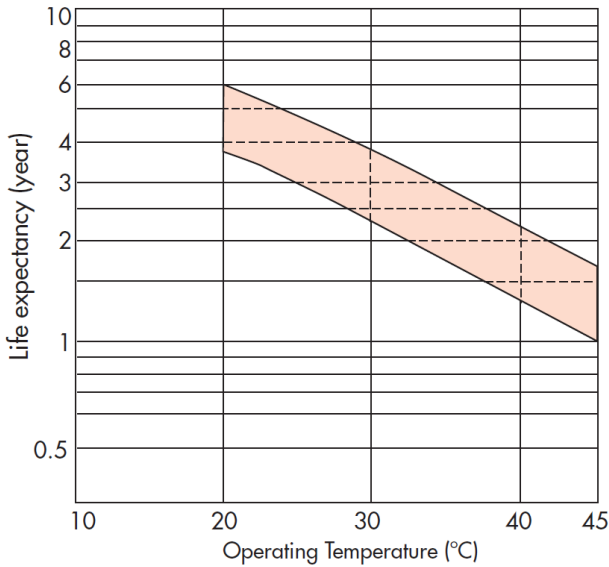

SoC vs OCV

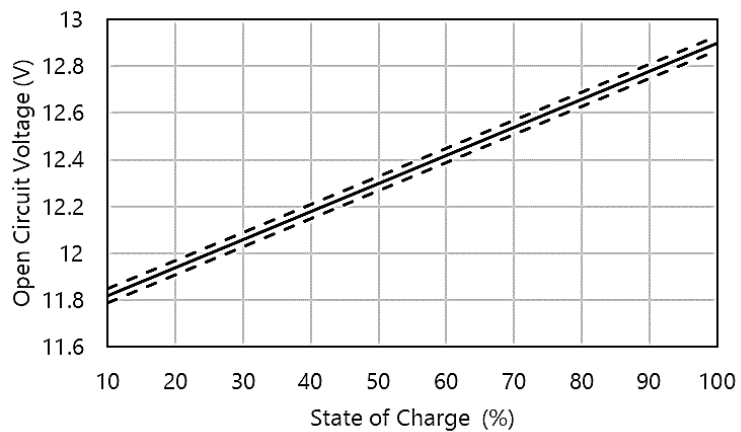

Storage & Supplementary Charge

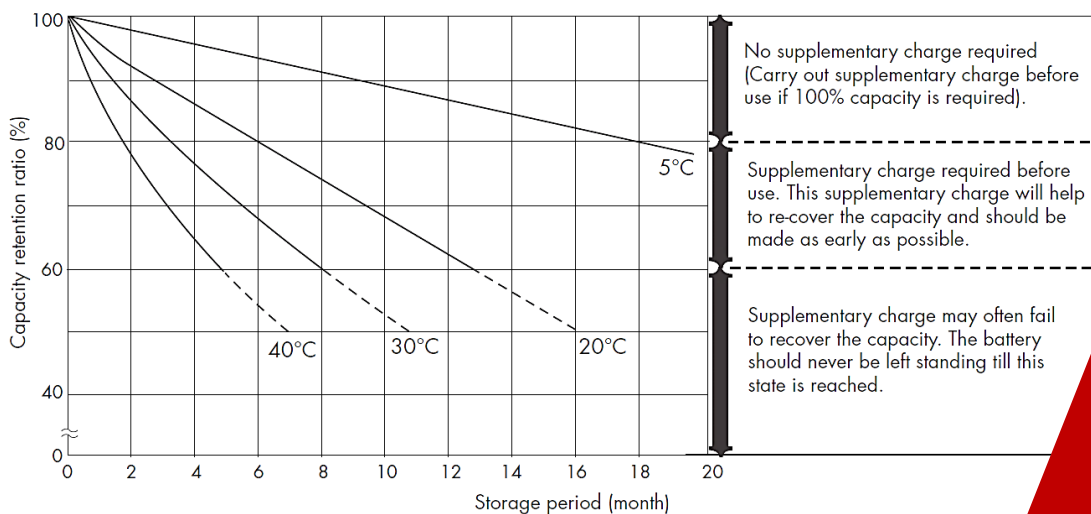

EHP12-390W

Product Outline

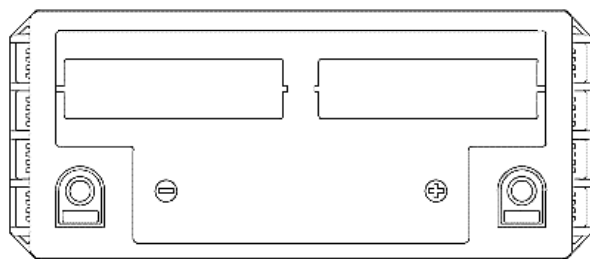
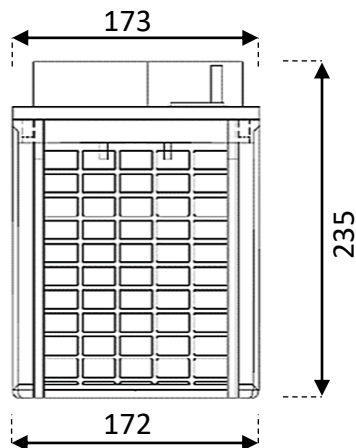
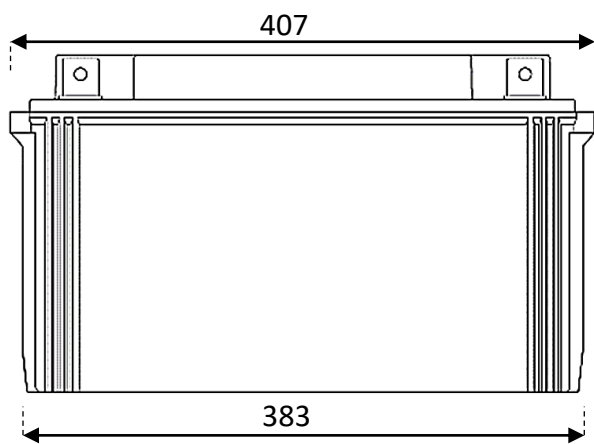

Terminal View

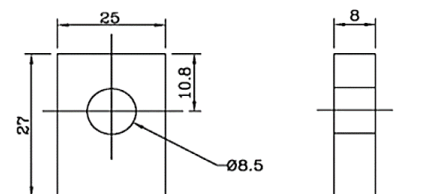

[M8 BOLT & NUT]

Constant Power Discharge Rating Per Cell at 27° C

ECV	Duration					
	10 min	15 min	20 min	25 min	30 min	60 min
1.67	488	390	325	283	232	142
1.70	483	386	318	276	230	134
1.75	468	378	309	267	228	126
1.80	461	365	288	249	220	123

** Please note, the above discharge values are average and can be achieved within 5 charge/discharge cycles

Charging Characteristics

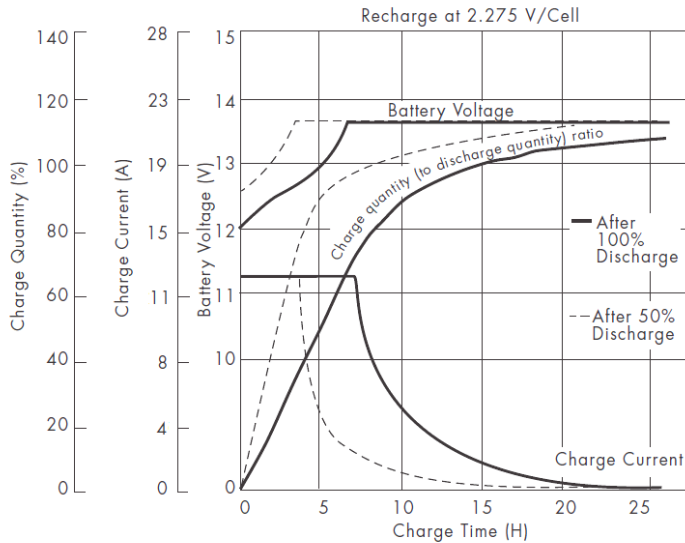

Charging Current

Minimum	10.5A
Maximum	26A

Other Information

Terminal Torque	12.3 N-m
Short Circuit Current	2100A
Cable Sizing	2A/mm ²
Max Cable Drop	<20mV/meter

EHP12-440W

Product Outline

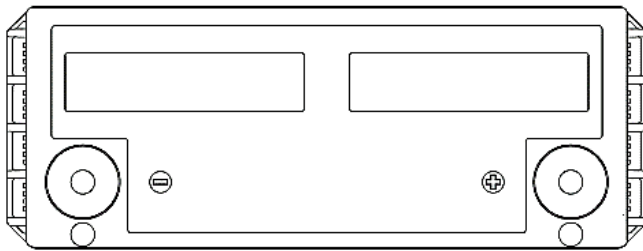
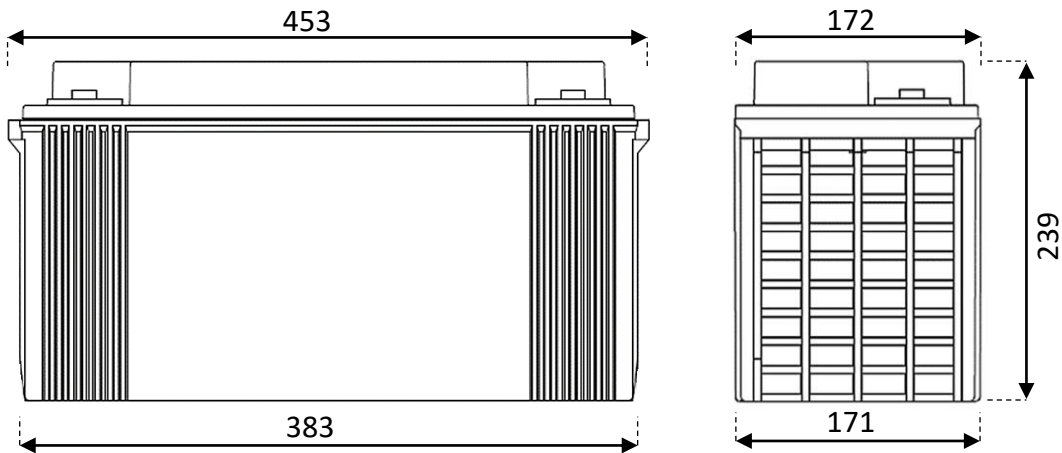

Terminal View

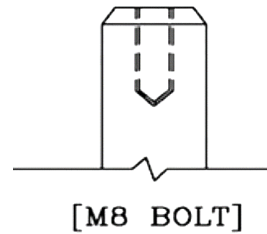

Constant Power Discharge Rating Per Cell at 27° C

ECV	Duration					
	10 min	15 min	20 min	25 min	30 min	60 min
1.67	510	440	376	318	279	158
1.70	506	438	364	309	276	151
1.75	485	432	344	293	273	144
1.80	461	401	331	281	268	139

** Please note, the above discharge values are average and can be achieved within 5 charge/discharge cycles

Charging Characteristics

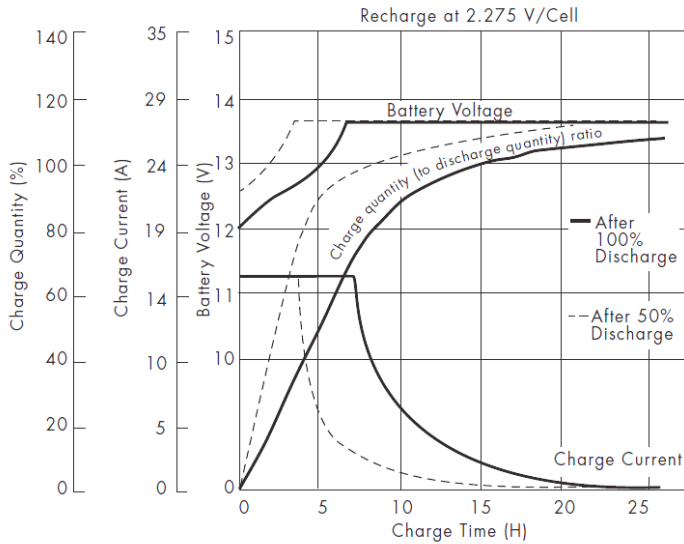

Charging Current

Minimum	12.5A
Maximum	31A

Other Information

Terminal Torque	12.3 N-m
Short Circuit Current	2500A
Cable Sizing	2A/mm ²
Max Cable Drop	<20mV/meter

EHP12-540W

Product Outline

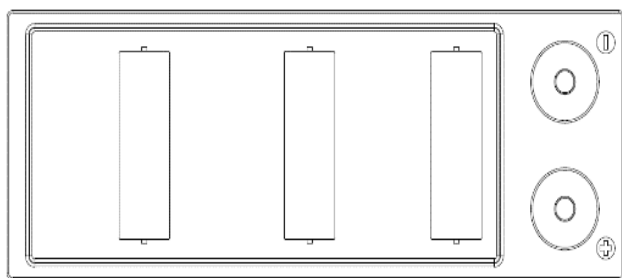
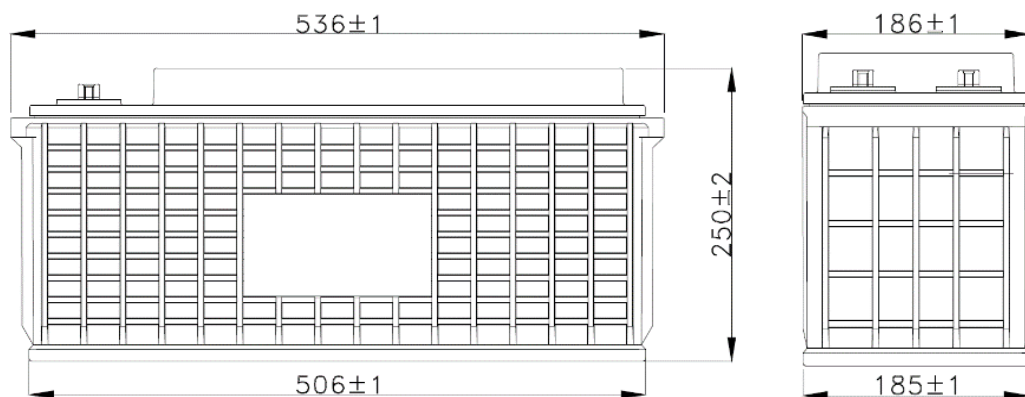

Terminal View

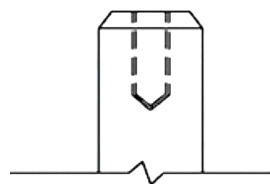

[M8 BOLT]

Constant Power Discharge Rating Per Cell at 27° C

ECV	Duration					
	10 min	15 min	20 min	25 min	30 min	60 min
1.67	625	540	467	383	331	193
1.70	620	536	433	349	326	189
1.75	616	520	399	332	322	181
1.80	590	497	367	322	317	175

** Please note, the above discharge values are average and can be achieved within 5 charge/discharge cycles

Charging Characteristics

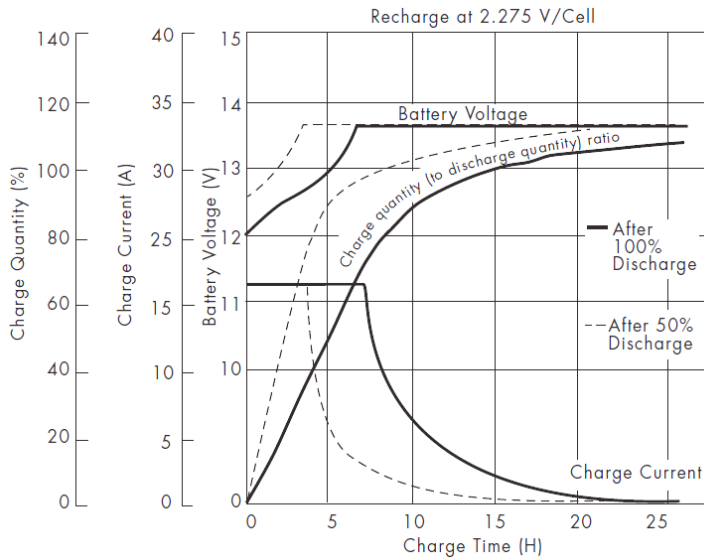

Charging Current

Minimum	15.5A
Maximum	39A

Other Information

Terminal Torque	12.3 N-m
Short Circuit Current	3100A
Cable Sizing	2A/mm ²
Max Cable Drop	<20mV/meter

EHP12-730W

Product Outline

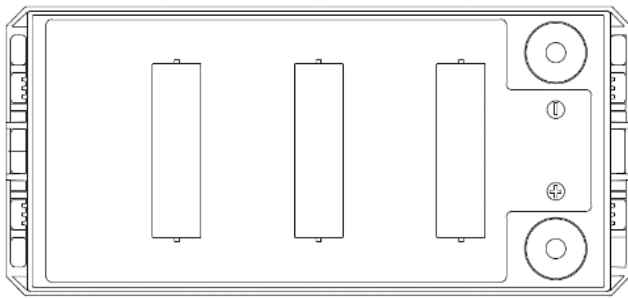
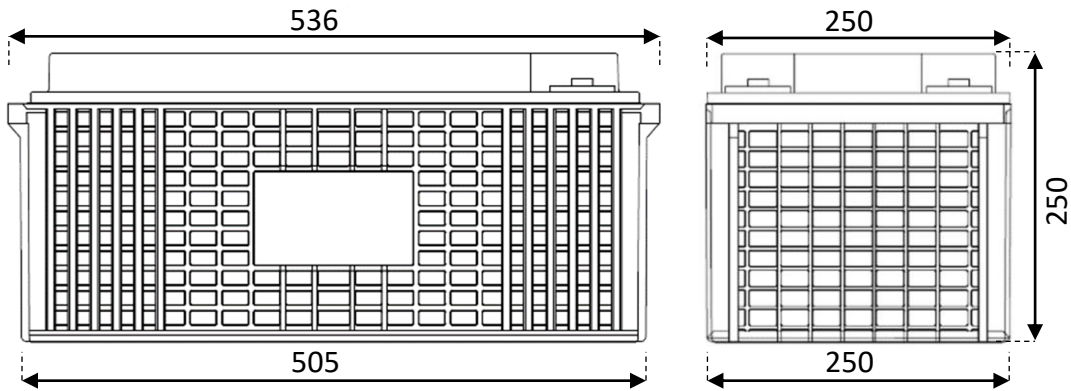

Terminal View

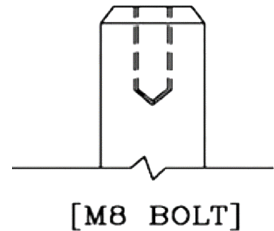

Constant Power Discharge Rating Per Cell at 27° C

ECV	Duration					
	10 min	15 min	20 min	25 min	30 min	60 min
1.67	880	730	601	520	441	253
1.70	868	718	584	502	433	243
1.75	834	683	552	468	423	234
1.80	801	653	509	434	411	226

** Please note, the above discharge values are average and can be achieved within 5 charge/discharge cycles

Charging Characteristics

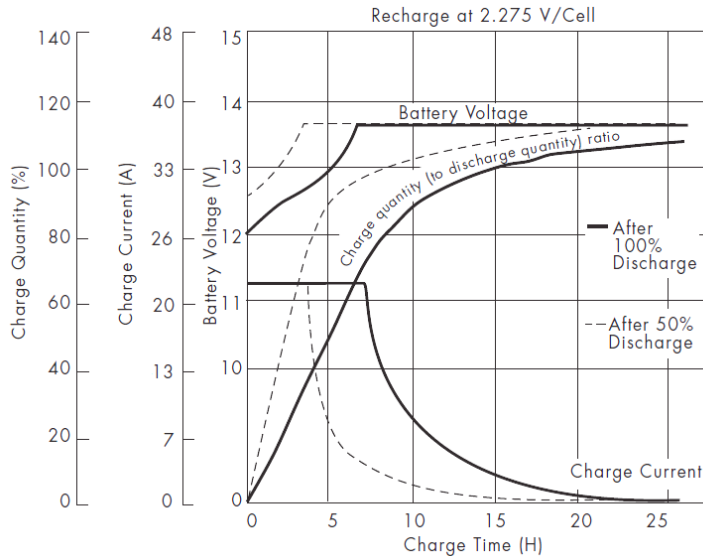

Charging Current

Minimum	21A
Maximum	53A

Other Information

Terminal Torque	12.3 N-m
Short Circuit Current	4100A
Cable Sizing	2A/mm ²
Max Cable Drop	<20mV/meter

Corporate Office: Exide Industries Limited
 Exide House 59E, Chowringhee Road, Kolkata – 700020
 Ph: (033)23023460
 Corporate Website : www.exideindustries.com

Marketing Office: Exide Industries Limited
 6A, Hatibagan Road, Kolkata – 700014
 Ph: (033) 23023601 Ph: (033)23023460